



绿色动力环保集团股份有限公司

GREENPOWER ENVIRONMENTAL PROTECTION GROUP CO., LTD.



1		<p style="text-align: right;">3.2.4 3.2.7</p> <p style="text-align: center;">3.2.4 3.3.4 1.3</p> <p style="text-align: center;">3.3 4</p>
2	/	<p style="text-align: center;">/</p> <p style="text-align: center;">4.1.1 4.1.2</p> <p style="text-align: center;">4.2.2 7</p> <p style="text-align: center;">21 28</p> <p>29</p> <p style="text-align: center;">3 5</p>
3	/	<p>GB18597-2023</p> <p style="text-align: center;">HJ1276-2022</p> <p style="text-align: center;">4.1.4 4.2.3</p> <p style="text-align: right;">/</p> <p style="text-align: center;">16 17 20</p> <p style="text-align: center;">=</p>

4

300m

		6.3
6	/	<p>7 19 /</p> <p>21 23</p> <p>3-7 4 11-24 30</p>

.....

.....

.....

.....

.....

.....

.....

.....

.....

.....

.....

.....

.....

.....

.....

.....

.....

.....

.....

.....

.....

.....

.....

.....

.....

.....



---

---







.....  
.....  
.....  
.....  
.....  
.....  
.....  
.....  
.....  
.....  
.....  
.....  
.....  
.....



---

# 1.

## 1.1.

"

"

## 1.2.

"

"

---

2023 9 8

"

"

**1.3.**

"

"

**1.4.**

"

"





---

5

6

7

8

9

10

11

12

13

14

15

16

17

18

19

### **2.3.**

1

2

3

2023 9

4

5

6

---

### 3.

#### 3.1.

##### 3.1.1.

2013 8  
2011 3 31

[2011]230

2019 8 28  
SCR 2020 9  
SCR 2021 12 22 SCR 2022 1  
11



	/					
		SNCR+	+	+	+	+SCR
		250m <sup>3</sup> /d 2				" +UASB
			+ A/O +	+	+	"
			1500m <sup>3</sup>			
			1500m <sup>3</sup>			

**3.1.2.**

			2599.72
			119.275
			223.49
			145.62
		20%	249.38
			685.62

---

### 3.1.3.

	4		350t/d		3
	5		SLC350- 4.0/450-1 31.1t/h 4.0MPa g		3
	6				3

---

**3.1.4.1.**

---

**3.1.4.2.**

-

T                      CO                      2

**3.1.4.3.**

**3.1.4.4.**

SNCR + + + +

170

SCR

80m

1

170

2

---

**3.1.4.5.**

---

**3.1.4.6.**

			9	2%
			9	
1.5m	6.0m		0.5m	1.0m
20m	5.5m	2.5m	-8.50m	





---

**3.1.5.**

---

**3.1.6.** "

"

"

"

**3.1.7.**

	2021	12	22	SCR
2022	1	11		

		70.55	

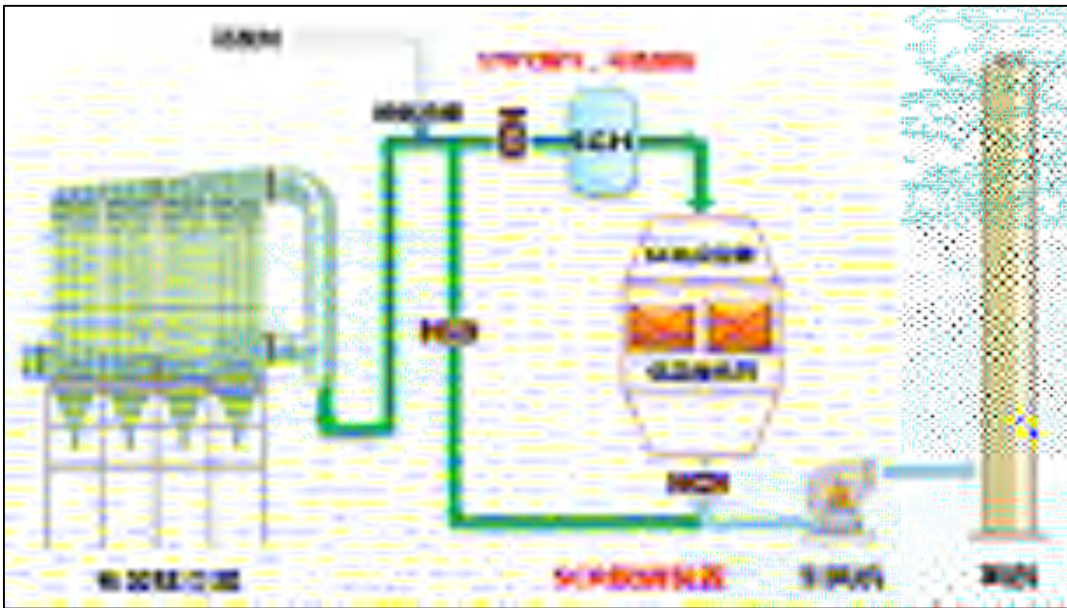





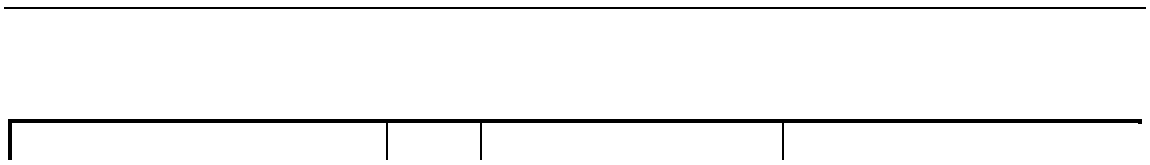

---

**3.2.3.**

**3.2.4.**







---

--	--	--	--

---

---

### 3.2.5.

1		SLC600-6.4/450	2		
2		LSLP600	2		
3			2		
4			2		
5		1400BSBD65C	2		
6		DY100FHD	2		
7		MOB-YEF-3.5	4		
8		MLB-YEF-19	4		
9		N160WMQD-8	3		
10		1960BSBBF65C	2		
11		TXF-60C	2		
12		600t/d	2		+ + +
13		600t/d	2		SNCR +SCR
14		8-10t/h	1		
15		N30-6.3	1		
16		NCR-H6J09112-FL3	3		



---

**3.2.6.4.**

**3.2.6.5.**

**3.2.6.6.**

**3.2.6.7.**

**3.2.7.**



### 3.2.8.

"

"

"

"

		t/a	t/				
1			144722				
2							
3				0			
4				0			
5	Ca(OH) <sub>2</sub>	5200	1631.46				
6		200	58.37				
7		5	0				
8		2000	437.3				
9			0			/	
10	0#	339	114.16				
11		480	86.61				
12		1600	0		/	/	

---

**3.2.9.**



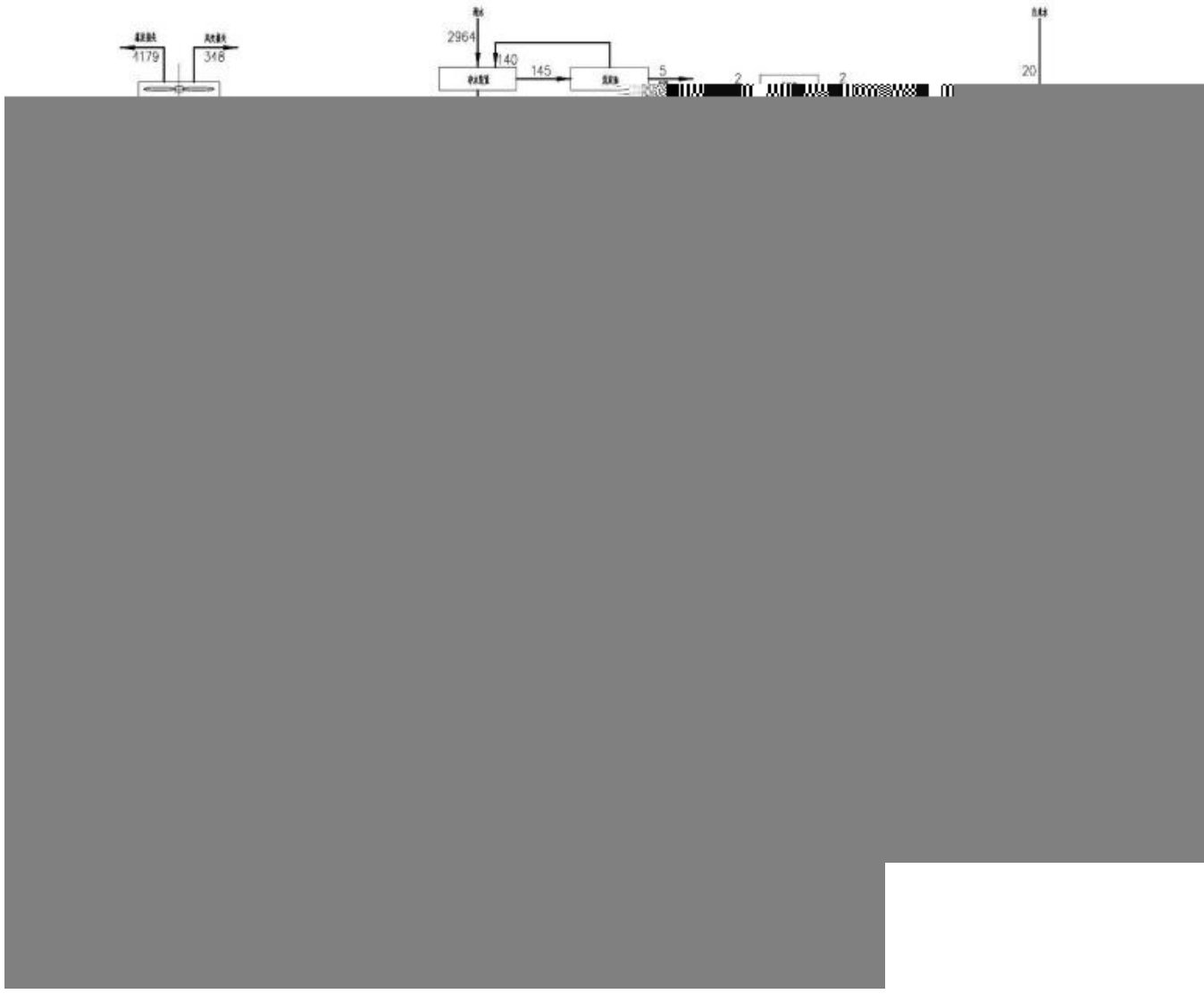

---

### **3.2.10.**

#### **3.2.10.1.**

×

---

---

---

---

---





"

"

### **3.2.10.2.**





---

**3.2.10.3.**

**3.2.10.4.**

---

**3.2.10.5.**

**3.2.10.6.**

1



" "

---

**3.2.10.7.**

**3.2.10.8.**



"

"

"

"



"

"







---

### 3.3.

#### 3.3.1.

"

"

"

"

#### 3.3.2.

##### 3.3.2.1.

"

"

"

"

---

### **3.3.2.2.**

"

"

"

"

### **3.3.3.**

#### **3.3.3.1.**



	30m <sup>3</sup> 1	250m <sup>3</sup> 1		
	30m <sup>3</sup> 60m <sup>3</sup>	40m <sup>3</sup> m <sup>3</sup> 120m <sup>3</sup>		

"

"

---

		2.	30%	



		6.		" "
		1		" "
		2		" "
		3		" "
		4	10%	" "
		7.	10%	" "

8.

6

10

" "

" "

" "

" "

---

		10.	10	
		11.		
		12.		



---

## 4.

### 4.1.

#### 4.1.1.

"

"

"

"

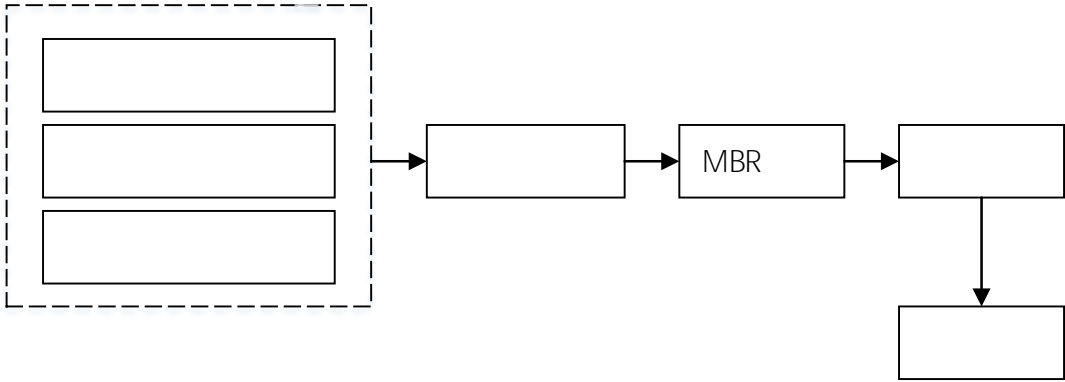

"

"

---

[ ]

UASB

[ ]

[ ]

[ ]

[ ]

[ ]

[ ]

[ ]

"

"

+

+

+

"

"



## 4.1.2.

### 4.1.2.1.

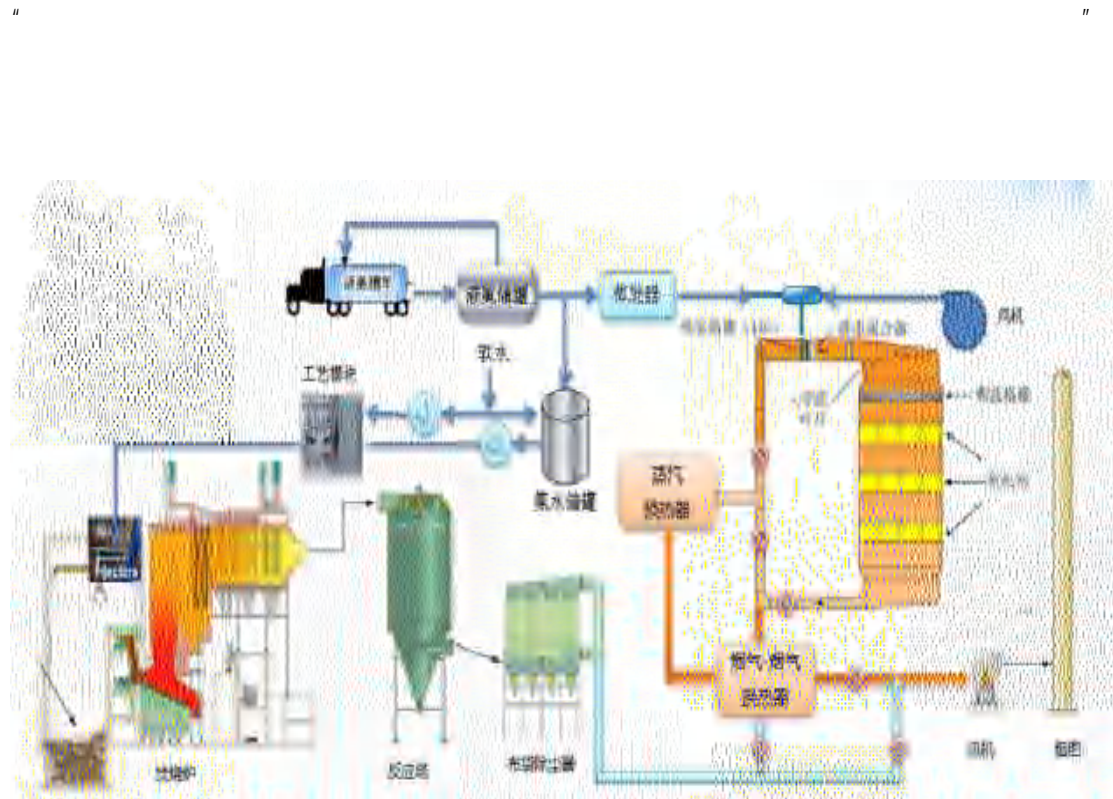

---



---

1

2

**4.1.2.2.**





---

**4.1.3.**



---

#### **4.1.4.**

**1**

**2**

**3**

**4**



---

**4.2.**

**4.2.1.**



---

## 4.2.2.

### 4.2.3.

1

" "

" "

		7cm/s	100mmC15 +20m1:3 +2 1.5mm +40mm 50mm +1.5mm +1.2m
			100mmC15 +20mm1 2.5 +2.0mmHDPE +500mmC30
	/		300mm +100mm +C25 +2mm + +150mmC25
		7cm/s	

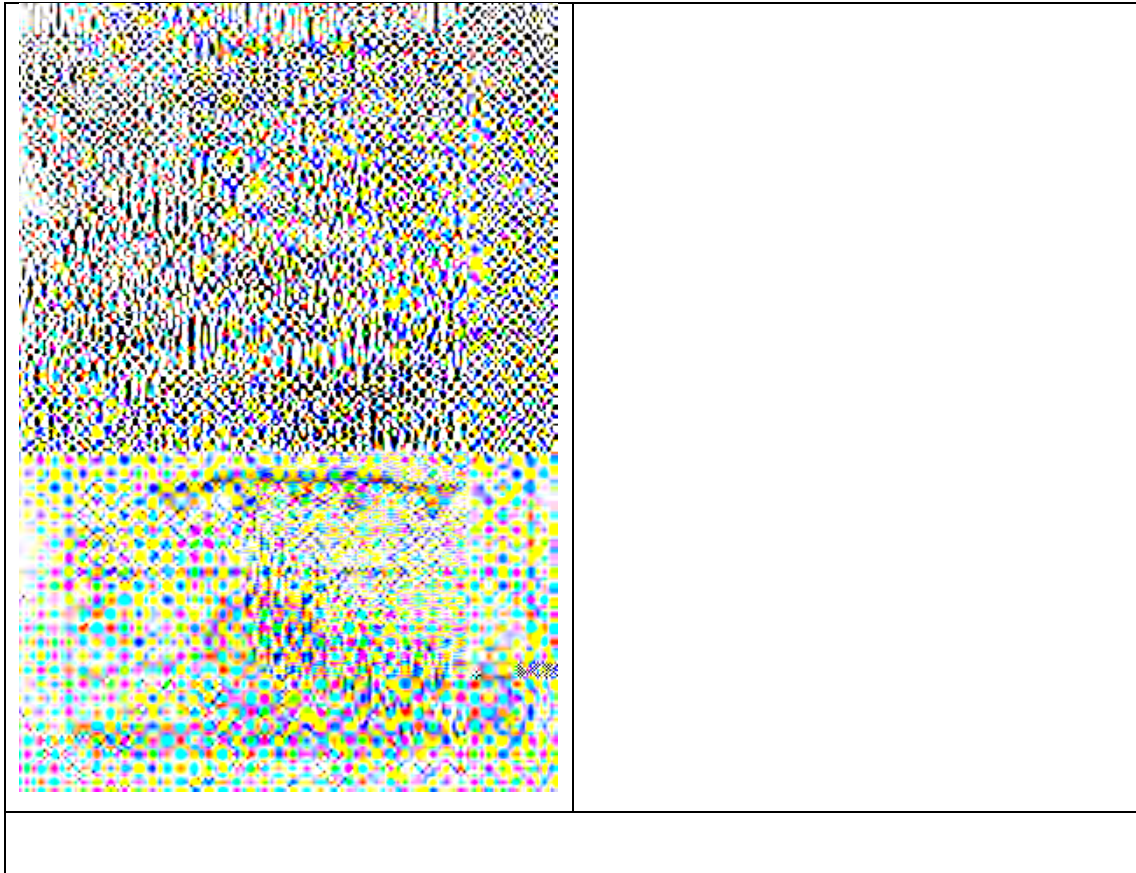

---

---

**4.3.**

**4.3.1.**

---

--	--	--	--



---



---

---

## **5.**

### **5.1.**

#### **5.1.1.**

#### **5.1.2.**

" "



---

### 5.1.3.

#### 5.1.3.1.

+                      +SNCR                      SNCR+                      +                      +

#### 5.1.3.2.

#### 5.1.3.3.

---

**5.1.4.**

**5.1.4.1.**

---

2008 82

300m

**5.1.4.2.**

"

"

---

**5.1.4.3.**

**5.1.4.4.**

"

"

**5.1.4.5.**

---

**5.1.4.6.**

**5.1.4.7.**

---

**5.1.5.**

**5.2.**



"

---

"

"





---

## 6.

### 6.1.

#### 6.1.1.

--	--	--	--	--

---

**6.1.2.**



---

**6.1.3.**

**6.1.4.**



## 6.2.

### 6.2.1.

2012	GB3095-	PM <sub>10</sub>	-	0.15	0.070
		PM <sub>2.5</sub>	-	0.075	0.035
		SO <sub>2</sub>	0.50	0.15	0.060
		NO <sub>2</sub>	0.20	0.08	0.040
		NO <sub>x</sub>	0.25	0.1	0.050
		TSP	-	0.3	0.2
		Pb	-	-	0.0005
		Cd	-	-	0.000005
		Hg	-	-	0.000005
HJ 2.2-2018	D	NH <sub>3</sub>	-	0.20	-
		H <sub>2</sub> S	-	0.01	-
		HCl	-	0.05	-

---

pgTEQ/m <sup>3</sup>		-	-	0.6

**6.2.2.**





---

**6.2.3.**

			mg/L	
			mg/L	
			mg/L	
			mg/L	

### 6.3.

	(	(	(	(
SO <sub>2</sub>	56.59	/	56.59	
NO <sub>x</sub>	150.92	79.26	71.66	
	18.86	/	18.86	

---

# 7.

## 7.1.

		2023.7.28~7.29		
		2023.7.26~7.27		
		2023.7.26~7.27		
		2023.7.27~7.28		
		2023.7.26~7.27		
		2023.9.6~9.7		
		2023.7.28~7.29		
		2023.9.6~9.7		
		2023.7.26~7.29		
		2023.9.6~9.7		
		2023.7.29		
		2023.7.28		

### 7.1.1.

---

**7.1.2.**

---

**7.1.3.**

---

**7.1.4.**

**7.1.5.**

				5%	

**7.2.**

**7.2.1.**

---

--	--	--	--	--	--

---

---

				pH			



---

# 8.

## 8.1.

		3 mg/m <sup>3</sup>	
		3 mg/m <sup>3</sup>	
		3 mg/m <sup>3</sup>	
		mg/m <sup>3</sup>	MS105DU 11800420110050

			mg/m <sup>3</sup>
			mg/m <sup>3</sup>
			0.0 7 mg/m <sup>3</sup>
		HJ 534- 2009	0.00 mg/m <sup>3</sup>
		) 2007	0.001 mg/m <sup>3</sup>

		GB/T 11901-1989	ME204/02 (11800420110140)

		0.5 mg/L	MP516 11800921020337	
			ICP Avio 200 (11800220110042)	
			ICAP 7400 2-HY-2016-18	
			50ml 11800920110171	
			UV-7504 (11800920110064)	
			UV-7504 (11800920110064) (11800921030354)	

CIC-D100  
1150L0108  
AQ-1100  
11800222050539

---

		0.004	UV-7504 (11800920110064)



---

.

		0.00005	
		0.00009	
		0.02	
		0.004	
		0.02	
		0.006	
		0.004	
		:0.016	
		:0.016	
		0.05	
		0.02	
		0.02	
		0.03	
		0.02	
		:5	
		:5	
			Aquion-1100 11800220110062
			50ml (11800920110171)

---

US



---

---

**8.3.2.**

	2023.07.	mg/L	0.04	0.04			
		mg/L	0.006	0.006			
			ND	ND			
			0.14	0.15	3.4		
			0.83	0.88	2.9		
			2.0	1.9	2.6		
			0.18	0.19	2.7		
		mg/L	ND	ND			
					0.9		
			ND	ND			
	2023.07.	mg/L	ND	ND			
					2.2		
					2.0		
			ND	ND			
					3.7		
					2.4		
	2023.07.				0.5		
	2023.07.				0.4		
	2023.07.	mg/L	0.03	0.03			
		mg/L	0.004	0.004			

			ND	ND			
	2023.07.		ND	ND			
	2023.07.	mmol/L					
	2023.07.	mmol/L					
	2023.07.	mmol/L					
	2023.07.				6.2		
	2023.07.				2.1		
					0.6		
					5.9		
	2023.09.06	mg/L	ND	ND	0		
			ND	ND	0		

			ND	ND	0		
			9	10	5.3		
			688	690	0.1		
		mg/L	0.02	0.02	0		
		mg/L	ND	ND	0		
			47.8	48.1	0.3		
			0.06	0.07	7.7		
			1.05	1.05	0		
			ND	ND	0		
			0.29	0.26	5.5		
		( mg/L)			0.5		
		( mg/L)	6.88	6.88	0		
					0.3		
		mg/L	ND	ND	0		
			ND	ND	0		
			ND	ND	0		
			10	11	4.8		
			401	402	0.1		
		( mg/L)			0.2		
		( mg/L)	0.218	0.194	5.8		
			ND	ND	0		
	2023.09.06	mmol/L					

	2023.09.07	mmol/L					
	2023.09.06		ND	ND	0		
			10	10	0		
			0.793	0.778	1.0		
	2023.09.07		ND	ND	0		
			9	10	5.3		
			0.512	0.518	0.6		
			0.36	0.40	5.3		
			ND	ND	0		
			ND	ND	0		
			0.26	0.30	7.1		
			0.09	0.06	20.0		
			ND	ND	0		
			ND	ND	0		
			ND	ND	0		
			ND	ND	0		
			0.42	0.37	6.3		
			ND	ND	0		
			0.52	0.57	4.6		
			ND	ND	0		
			3.7	3.7	0		
					0		

			ND	ND	0		
			ND	ND	0		
			0.27	0.27	0		
			ND	ND	0		
			ND	ND	0		
			ND	ND	0		
			4.3	4.1	2.4		
			2.2	2.2	0		
			0.57	0.56	0.9		
			5.02	4.86	1.6		
			8.39	8.29	0.6		

			3.63	3.53	1.4		
			3.36	3.30	0.9		
			ND	ND	0		
			29.5	29.7	0.3		
					0.1		
					0.6		
					0		
					0		
					0		
					1.0		
					0		
					1.6		
					0		
			14.7	14.8	0.3		
			ND		0		
			23.0	23.0	0		
			120	120	0		
			17.3	17.3	0		
			1.00	1.00	0		
			36.0	36.0	0		
			106	104	1.0		
			ND	ND	0		



			ND	ND	0		
			0.10	0.11	4.8		
			ND	ND	0		
			ND	ND	0		
			ND	ND	0		
			ND	ND	0		
			ND	ND	0		
			ND	ND	0		
	DXS05 2# 2023.09.06		1.66				
					2.1		
					0		
					0		
					0		
					0.6		
					0		
					1.8		
					2.7		

			25.0	24.9	0.2	
			ND	ND	0	
			9.04	9.00	0.2	
			66.4	66.3	0.1	
					0	
			2.18	2.18	0	



			ND	ND	0		
			1.38	1.34	1.5		
			ND	ND	0		
			ND	ND	0		
			1.1	1.1	0		
					0		
					0		
					0.9		
					0.5		
			28.4	28.4	0		
			7.71	7.71	0		



			133	138	1.8		
			0.24	0.24			
			0.36	0.37	1.9		
		pH				pH	

			2.023	0.000	2.000	101	
			2.095	0.000	2.000	105	
			2.166	0.000	2.000	108	
			2.272	0.000	2.000	114	
			2.129	0.000	2.000	106	
			2.212	0.000	2.000	111	
			2.182	0.000	2.000	109	
			1.758	0.000	2.000	87.9	
		QC-32hun- KBJB-230801-1					

			2.034	0.000	2.000	102		
			1.912	0.000	2.000	95.6		
		QC-32hun- KBJB-230808-3	1.966	0.000	2.000	98.3		
			1.971	0.000	2.000	98.6		
			2.044	0.000	2.000	102		
			1.997	0.000	2.000	99.8		
			2.027	0.000	2.000	101		
			2.034	0.000	2.000	102		
			2.031	0.000	2.000	102		
			2.106	0.000	2.000	105		
			2.029	0.000	2.000	101		
			1.872	0.003	2.000	93.4		
			QC-32hun-KBJB- 230801-2	0.9815	0.0000	1.0000	98.2	
				0.9535	0.0000	1.0000	95.4	
		QC-32hun- KBJB-230731-02	10.65	0.00	10.00	106		
			10.70	0.00	10.00	107		
						80%- 120%		
		QC-32hun- KBJB-230801-5	0.906	0.000	1.000	90.6		
			1.062	0.000	1.000	106		
			0.964	0.000	1.000	101		
						70%- 120%		

		QC-32hun- KBJB-230911-05	19.55	0.00	20.00	97.8	
			19.55	0.00	20.00	97.8	
						80%- 120%	
		QC-32hun- KBJB-230912-2	1.049	0.000	1.000	105	
			1.047	0.000	1.000	105	
			1.042	0.000	1.000	104	
			10.600	0.100	10.000	105	
			11.125	0.000	10.000	111	
			9.800	0.000	10.000	98.0	
			9.950	0.000	10.000	99.5	
		QC-32hun- KBJB-230911-03	9.775	0.000	10.000	97.8	
			9.700	0.000	10.000	97.0	



			9.825	0.000	10.000	98.2	
			9.875	0.000	10.000	98.8	
			9.800	0.000	10.000	98.0	
			9.925	0.000	10.000	99.2	
			9.800	0.000	10.000	98.0	
		QC-32hun-KBJB-230911-01	42.0	0.0	40.0	105	
			39.3	0.0	40.0	98.2	
			38.7	0.0	40.0	96.8	
			38.0	0.0	40.0	95.0	
			38.8	0.0	40.0	97.0	
		QC-32hun-KBJB-230908-2	1.064	0.000	1.000	106	
			1.037	0.000	1.000	104	
		QC-32hun-KBJB-230912-1	0.514	0.000	0.500	103	
			0.530	0.000	0.500	106	
		QC- - HCI0614H1101- JB	0.0115	0.1076	0.1000	96.1	
		QC- - HCI0614H2101- JB	0.0220	0.1155	0.1000	93.5	

		QC-Cr <sup>6+</sup> -KBJB- 20230809-01	21.1	0.0	20.0	106		
		QC-SVOC- 230731		0.00	5.00			
	2-			0.00	5.00			
				0.00	5.00			
				0.00	5.00			
				0.00	5.00			
				0.00	5.00			
				0.00	5.00			
				0.00	5.00			
				0.00	5.00			
				0.00	5.00			
			-d5		0.00	5.00		
			4,4'- -d14		0.00	5.00		
	1,1-							

	-1,2-						
	1,1-						
	-1,2-						
	1,1,1-						
	1,2-						
	1,2-						
	1,1,2-						
	1,1,1,2-						
	-						
	-						
	-						
	1,1,2,2-						
	1,2,3-						
	1,4-						

	1,2-						

		QC-Hg-202056-1	1.50	1.64±0.19	
		QC-Hg-202056-1	1.49	1.64±0.19	
		- B23010142-3	0.762	0.800±0.058	
		- ( )-206914-6-1	1.35	1.39±0.06	
	g/	QC-GSS-3a-3	0.113	0.116±0.005	
		- ( )-206914-6	1.36	1.39±0.06	
		- ( )-206914-6	1.37	1.39±0.06	
		- B23010142-3	0.762	0.800±0.058	
		- B23010142-3	0.755	0.800±0.058	



	mmol/L	-200752-7	3.57		
			65.4		
			64.7		
			65.2		
		QC-Hg-202056-1	1.66	1.64±0.19	
		QC-As-200454-3	39.0	38.3±3.5	
			6.45		

		- B22050028-6	5.28	5.24±0.26	
		- B22050028-6	5.26	5.24±0.26	
		QC-Hg-202056-1	1.68	1.64±0.19	
		QC-Hg-202056-1	1.61	1.64±0.19	
		QC-As-200454-3	41.7	38.3±3.5	
			38.7	38.3±3.5	

		-	-B221100241-1	20.0	19.4±1.0	
		-	-B22030114-1	5.63	5.62±0.51	
	mmol/L		-200752-9-1			
	mmol/L		-200752-9			



# 9.

## 9.1.

	t/d		t/d		t/d		t/d	%	
	4#	5#	4#	5#	4#	5#			
2023.7.26	600+600		367.19	404.49	0		166.38	78.5	24.1
	1200		771.68		0		244.88		
2023.7.27	600+600		427.91	465.67	0		117.99	22.37	13.6
	1200		893.58		0		140.36		
2023.7.28	600+600		496.08	375.44	0		38.181	81.4	12.1
	1200		871.52		0		119.581		
2023.7.29	600+600		505.12	171.81	0		78.75	95.63	20.5
	1200		676.94		0		174.38		
2023.9.6	600+600		370.41	312.44	0		167.15	200.13	35.0
	1200		682.85		0		367.28		
2023.9.7	600+600		385.54	352.13	0		151.28	213.23	33.1
	1200		737.67		0		364.51		
= /									

					%
3#	2023.7.26	240000000	720000	509220	70.73%
	2023.7.27	240000000	720000	519930	72.21%
	2023.7.28	240000000	720000	535860	74.43%
	2023.7.29	240000000	720000	453090	62.93%
	2023.9.6	240000000	720000	725370	100.75%
	2023.9.7	240000000	720000	726180	100.86%



## 9.2.

### 9.2.1.





---

			2023.7.28			2023.7.29			7.28	7.29		
						1	2	3				
			1.3	1.8	1.8		1.1	1.1	1.8	1.1	--	
			1.0	1.4	1.4		0.9	1.0	1.4	1.0		

$8.6 \times 10^{-2}$

									7.28	7.29		
			2023.7.28			2023.7.29						
						1	2	3				
1.ND			9.43×10 <sup>-3</sup>			1.07×10 <sup>-2</sup>			9.43×10 <sup>-3</sup>	1.07×10 <sup>-2</sup>	--	
			7.56×10 <sup>-3</sup>			9.34×10 <sup>-3</sup>			7.56×10 <sup>-3</sup>	9.34×10 <sup>-3</sup>		
			8.5×10 <sup>-4</sup>			9.1×10 <sup>-4</sup>			8.5×10 <sup>-4</sup>	9.1×10 <sup>-4</sup>	--	

									7.26	7.27		
			2023.7.26			2023.7.27						
						1	2	3				
			3.3	3.0	3.2	1.5	1.2	1.6	3.3	1.6	--	
			2.7	2.5	2.6	1.1	1.0	1.2	2.7	1.2		
			0.22	0.21	0.23	9.3×10 <sup>-2</sup>	9.4×10 <sup>-2</sup>	0.10	0.23	0.10		
			30	31	40	39	19	8	40	39	--	
			24	26	32	30	16	6	32	30		
			2.0	2.2	2.8	2.4	1.5	0.51	2.8	2.4		
			43	35	37	56	79	92			--	
			35	29	30	43	67	71				
			2.9	2.4	2.6	3.5	6.2	5.9				
			11.0	19.2	11.6	6.85	13.1	4.29			--	
			8.94	16.1	9.35	5.23	11.1	3.30				
			0.75	1.3	0.83	0.43	1.0	0.28				
						11	5	6			--	
						8	4	5				

									7.26	7.27		
			2023.7.26			2023.7.27						
						1	2	3				
			/	/	/	0.68	0.39	0.38	/			
			$1.1 \times 10^{-5}$	$2.3 \times 10^{-5}$	$2.1 \times 10^{-5}$	$1.0 \times 10^{-5}$	$4.5 \times 10^{-5}$	$8.2 \times 10^{-5}$	$2.3 \times 10^{-5}$	$8.2 \times 10^{-5}$	--	
			$1.3 \times 10^{-5}$	$2.2 \times 10^{-5}$	$2.0 \times 10^{-5}$	$1.0 \times 10^{-5}$	$4.2 \times 10^{-5}$	$8.3 \times 10^{-5}$	$2.2 \times 10^{-5}$	$8.3 \times 10^{-5}$		
			$9.6 \times 10^{-7}$	$1.9 \times 10^{-6}$	$1.8 \times 10^{-6}$	$8.4 \times 10^{-7}$	$3.8 \times 10^{-6}$	$6.2 \times 10^{-6}$	$1.9 \times 10^{-6}$	$6.2 \times 10^{-6}$		
			$3.61 \times 10^{-5}$			$1.48 \times 10^{-5}$			$3.61 \times 10^{-5}$	$1.48 \times 10^{-5}$	--	
			$3.01 \times 10^{-5}$			$1.35 \times 10^{-5}$			$3.01 \times 10^{-5}$	$1.35 \times 10^{-5}$		
			$2.8 \times 10^{-6}$			$1.1 \times 10^{-6}$			$2.8 \times 10^{-6}$	$1.1 \times 10^{-6}$	--	
			$9.12 \times 10^{-3}$			$3.93 \times 10^{-3}$			$9.12 \times 10^{-3}$	$3.93 \times 10^{-3}$	--	
			$7.54 \times 10^{-3}$			$3.54 \times 10^{-3}$			$7.54 \times 10^{-3}$	$3.54 \times 10^{-3}$		
			$6.7 \times 10^{-4}$			$3.1 \times 10^{-4}$			$6.7 \times 10^{-4}$	$3.1 \times 10^{-4}$	--	
1.ND												

			2023.7.28			2023.7.29						
						1	2	3				
			85602	86973	91479	--	89391	91231	94183	--	--	--
			8.7	8.0	9.5	--	8.4	9.3	11.1	--	--	--
			0.0051	0.0034	0.0038	0.0051	0.0038	0.0037	0.0070	0.0070		

---

			<b>2023.7.26</b>				<b>2023.7.27</b>					
			70666	75414	79713	--	63804	68557	72355	--	--	--
			10.5	9.6	11.1	--	9.6	10.4	11.5	--	--	--
			0.021	0.013	0.016	0.021	0.010	0.012	0.013	0.013		



---

		<b>m</b>	<b>m<sup>2</sup></b>	<b>m/s</b>		<b>Pa</b>	<b>kPa</b>	<b>kPa</b>	<b>m<sup>3</sup>/h</b>	<b>m<sup>3</sup>/h</b>	<b>%</b>	<b>kPa</b>	<b>%</b>
		85											



			2023.7.26				2023.7.27				7.26	7.27		
							1	2	3	4				
			0.214	0.211	0.218	0.220	0.149	0.147	0.146	0.152				
			0.003	0.002	0.002	0.006	0.002	0.002	0.003	0.002	0.006	0.003		
			12	11	12		11	12	11		12	12		
			0.264	0.247	0.262	0.246	0.223	0.219	0.215	0.225				
			0.199	0.194	0.189	0.191	0.173	0.172	0.167	0.169				
			0.006	0.004	0.005	0.009	0.002	0.004	0.003	0.004	0.009	0.004		
			13	13	12		12	13	13		13	13		
			0.264	0.260	0.262	0.253	0.282	0.280	0.292	0.284				
			0.288	0.279	0.281	0.286	0.282	0.287	0.282	0.284				
			0.007	0.004	0.009	0.016	0.003	0.004	0.002	0.002	0.016	0.004		
			14	12	13		14	13	15		14	15		
			0.266	0.281	0.281	0.270	0.258	0.256	0.268	0.254				
			0.311	0.314	0.311	0.315	0.310	0.313	0.307	0.315				
			0.006	0.006	0.008	0.003	0.002	0.002	0.002	0.002	0.008	0.002		
			13	13	12		12	13	13		13	13		

(%)

---

(%)

(kPa)

(m/s)



	pH									7.6	7.6	6.5~8.5	/	
										18	19	--	/	mg/L
										4.1	4.8		0.3	NTU
		10	10	20	20	10	10	15	15	20	15		/	
										3.8	5.5		0.5	mg/L
										12	21		4	mg/L
		0.04	0.07	ND	0.03	0.06	0.09	0.07	0.06	0.07	0.09		0.02	mg/L
		0.006	0.007	0.008	0.008	0.008	0.010	0.009	0.009	0.008	0.010		0.004	mg/L
		106	108	161	159	158	155	158	157	161	158		0.007	mg/L
		7.9	7.9	12.1	12.0	11.7	11.9	11.9	11.9	12.1	11.9		0.2	mg/L
		189	191	287	287	268	269	267	267	287	269		0.05mmol/L	mg/L
		70.2	66.4	101	103	92.5	94.8	93.9	93.2	103	94.8		/	mg/L
		110	113	169	169	163	162	164	162	169	164		0.018	mg/L

	477	485	489	498	650	629	675	662	498	675		/	mg/L	
	0.30	0.16	0.08	0.10	0.20	0.15	0.10	0.11	0.30	0.20		0.06	mg/L	
	ND	ND	ND	ND	ND	ND	ND	ND	ND	ND		0.05	mg/L	
	$\times 10^3$	$1.8 \times 10^3$	$1.3 \times 10^3$	$1.7 \times 10^3$	$1.1 \times 10^3$	$1.2 \times 10^3$	$1.4 \times 10^3$	$1.8 \times 10^3$	1800	1800		20	/L	
	0.5	0.5	0.4	0.4	0.5	0.3	0.4	0.3			0.05	0.04	mg/L	
	ND	ND	ND	ND	ND	ND	ND	ND	ND	ND	0.05	0.004	mg/L	
	0.00014	0.00036	0.00028	0.00014	0.00042	0.00106	0.00020	0.00082			0.01	0.00005	mg/L	
	0.00086	0.00085	0.00047	0.00061	0.00102	0.00123	0.00080	0.00070			0.1	0.00011	mg/L	
	0.0020	0.0024	0.0030	0.0042	0.0027	0.0028	0.0030	0.0034			0.1	0.0003	mg/L	
	ND	0.00814	ND	0.00359	0.0411	0.0244	0.00687	0.0194			0.1	0.00009	mg/L	
	0.00018	0.00020	0.00012	0.00020	0.00020	0.00023	0.00005	0.00019			0.001	0.00004	mg/L	

	pH								7.4	8.0	6.5~8.5	/	

									9	8	--	/	mg/L
	1.8	1.8	1.9	1.9	1.8	1.7	1.9	2.0	1.9	2.0		0.3	NTU
	0	0	0	0	5	5	5	5	0	5		/	
									4.1	4.9		0.5	mg/L
									14	18			mg/L
	0.03	0.03	0.03	0.02	ND	ND	0.05	ND	0.03	0.05		0.02	mg/L
	0.004	ND	ND	ND	ND	ND	0.008	ND	0.004	0.008		0.004	mg/L
	13.6	13.3	13.4	13.7	19.2	19.1	10.3	10.2	13.7	19.2		0.007	mg/L
	1.5	1.3	1.4	1.4	1.5	1.3	1.1	1.1	1.5	1.5		0.2	mg/L
	15.0	12.0	18.0	18.0	39.0	26.0	28.0	14.0	18	39		0.05mmol/L	mg/L
	8.6	7.9	8.0	8.6	8.6	7.9	8.0	8.6	8.6	8.6		/	mg/L
	10.5	10.1	10.3	10.7	13.2	13.2	4.30	4.28	10.7	13.2		0.018	mg/L
									0.126	0.085		0.025	mg/L
	ND	ND	ND	ND	ND	ND	ND	ND	ND	ND		0.01	mg/L
	74	78	75	80	66	68	61	64	80	68		/	mg/L
	0.12	0.06	0.11	0.11	0.11	ND	0.10	0.13	0.12	0.13		0.06	mg/L
	ND	ND	ND	ND	ND	ND	ND	ND	ND	ND		0.05	mg/L
	×10 <sup>3</sup>	×10 <sup>2</sup>	×10 <sup>3</sup>	×10 <sup>2</sup>	×10 <sup>3</sup>	×10 <sup>3</sup>	×10 <sup>2</sup>	×10 <sup>2</sup>	1500	1800		20	/L
									0.2	0.2	0.05	0.04	mg/L



												/	/	
		4.7	4.5	4.1	4.5	5.2	5.4	5.3	5.2	4.7	5.4		/	mg/L
		1.3	1.2	1.3	1.2	1.4	1.3	1.3	1.3	1.3	1.4	0.2	0.04	mg/L
												/	MPN/100mL	



			3.7	4.2	3.4	4.6		
		mg/L	0.00038	0.00027	0.00043	0.00027		
		mg/L	0.40	0.42	0.38	0.50		
		mg/L	0.28	0.29	0.31	0.28		
		mg/L	0.08	0.07	0.09	ND		
		mg/L	ND	ND	ND	ND		
		mg/L	ND	ND	ND	ND		
		mg/L	0.54	0.52	0.55	0.60		
		mg/L	ND	ND	ND	ND		
		mg/L	ND	ND	ND	ND		
		mg/L	ND	ND	0.02	ND		
		mg/L	ND	ND	ND	ND		
		mg/L	ND	ND	ND	ND		
		mg/L	ND	ND	ND	ND		
		mg/L	ND	ND	ND	ND		
		mg/L	ND	ND	ND	ND		

**9.3.**

---



**9.4.**

**9.4.1.**

---

**9.4.2.**

4#				4#				%						
	1	2	3		1	2	3		1	2	3			
<b>2023.07.28</b>													/	
	kg/h								93.44	97.2	95.17	95.17	95.27	<b>90%</b>
	kg/h								74.71	81.05	72.5	76.32	76.09	<b>80%</b>
	kg/h								99.70	99.61	99.52	99.59	99.61	<b>99.9%</b>
	kg/h								97.47	87.14	94.68	95.23	93.10	<b>90%</b>
<b>2023.07.29</b>													/	
	kg/h								67.33	78.93	86.36	79.09	77.54	<b>90%</b>
	kg/h								71.67	71.71	76.82	72.92	73.40	<b>80%</b>
	kg/h								100	99.76	99.67	99.72	99.81	<b>99.9%</b>

5#				5#				%						
	1	2	3		1	2	3		1	2	3			
	kg/h													<b>80%</b>
	kg/h													<b>99.9%</b>
	kg/h													<b>90%</b>

## 9.5.

### 9.5.1.

			2023.7.26-7.27	2023.7.27-7.28		
	PM <sub>2.5</sub>	g/m <sup>3</sup>		33	75	
	PM <sub>10</sub>	g/m <sup>3</sup>		58	150	
		g/m <sup>3</sup>		95	300	
		g/m <sup>3</sup>		11	150	
		g/m <sup>3</sup>		17	80	
		g/m <sup>3</sup>		21	100	
		g/m <sup>3</sup>	4.2×10 <sup>-3</sup>	5.2×10 <sup>-3</sup>	0.05	
		g/m <sup>3</sup>	1.10×10 <sup>-3</sup>	1.96×10 <sup>-3</sup>	--	
		g/m <sup>3</sup>	1.16×10 <sup>-4</sup>	2.55×10 <sup>-4</sup>	0.005	
	PM <sub>2.5</sub>	g/m <sup>3</sup>			75	
	PM <sub>10</sub>	g/m <sup>3</sup>		33	150	
		g/m <sup>3</sup>		53	300	
		g/m <sup>3</sup>		10	150	
		g/m <sup>3</sup>		18	80	
		g/m <sup>3</sup>		22	100	
		g/m <sup>3</sup>	2.0×10 <sup>-3</sup>	4.0×10 <sup>-3</sup>	0.05	
		g/m <sup>3</sup>	1.28×10 <sup>-3</sup>	4.43×10 <sup>-3</sup>	--	
		g/m <sup>3</sup>	1.85×10 <sup>-4</sup>	4.58×10 <sup>-4</sup>	0.005	

			2023.7.26				2023.7.27				7.26	7.27		
			1	2	3	4	1	2	3	4				
		3		137	132	139		145	151	141	139	153	200	
		3		2	2	3		4	3	1	3	4	10	
		3											50	
		3									21	30	200	
		3									24	32	250	
		3									10	12	500	
		3		150	153	146		176	172	175	153	177	200	
		3		2	3	3		2	3	2	3	3	10	
		3											50	
		3									40	24	200	
		3									47	26	250	



---

		<b>2023.7.26</b>	<b>2023.7.27</b>		



---

	pH														
		mg/L													
		mg/L													
		mg/L		120	140		41.9	47.5		59.8	59.3		59.6	265	
		mg/L		14.8	14.8		32.7								

	mg/L		ND	ND		ND	ND		ND	ND		ND	ND		
	mg/L		0.00010	0.00009		ND	ND		0.00011	0.00010		ND	0.00011		
	mg/L		ND	ND		ND	ND		ND	ND		ND	ND		
	mg/L		1.00	1.01		2.80	2.81		0.732	0.734		2.72	2.00		
	mg/L		36.0	36.0		23.0	23.1		18.9	18.8		11.8	33.2		
	mg/L		105	131		124	120		140	134		57.6	161		
	mg/L		ND	ND		ND	ND		ND	ND		ND	ND		
	mg/L														
	pH														
	mg/L														

	mg/L		ND	ND		ND	ND		ND	ND		ND	ND	
	mg/L		9.02	23.5		0.341	0.313		ND	ND		ND	ND	
	mg/L		ND	ND		ND	ND		ND	ND		ND	ND	
	mg/L											0.182	0.222	
	mg/L		ND	ND		ND	ND		ND	ND		ND	ND	
	mg/L		ND	ND		0.0017	0.0019		0.0057	0.0047		0.0009	0.0006	
	mg/L		ND	0.00005		ND	ND		ND	0.00005		ND	ND	
	mg/L		ND	ND		ND	ND		ND					

---

	mg/L										
	mg/L		48.1	53.7		55.5	73.1		52.3	61.3	
	mg/L		46.0	57.0							

	mg/L		5.63	5.52		11.0	11.5		15.1	13.5		
	mg/L		11.2	10.7		13.9	14.2		11.7	10.4		
	mg/L		47.5	46.5		49.1	57.2		43.3	38.7		
	mg/L		ND	ND		ND	ND		ND	ND		
	mg/L											

pH

	mg/L		0.188	0.194		0.247	0.234		0.324	0.324		
	mg/L		ND	ND		ND	ND		ND	ND		
	mg/L		0.0022	0.0018		0.0016	0.0009		ND	ND		
	mg/L		ND	ND		ND	ND		0.00005	ND		
	mg/L		ND	ND		ND	ND		ND	ND		
	mg/L		ND	ND		ND	ND		ND	ND		
	mg/L		7.71	7.24		12.1	10.4		18.9	20.1		
	mg/L		14.4	16.0		18.4	20.6		12.4	12.6		
	mg/L		52.8	64.8		66.5	73.3		42.8	43.3		
	mg/L		ND	ND		ND	ND		ND	ND		
	mg/L											



9.5.3.

				/
	0.36	0.38		mg/kg
				mg/kg
	15.8	11.3		mg/kg
	60	63		mg/kg
	112	98		mg/kg
	54	46		mg/kg
	64	52		mg/kg
	136	141		mg/kg
	0.92			/
	S3	S4		
	8.85	10.5		
	0.24	0.25	65	
	ND	ND	5.7	
	46	40	18000	
	54	63	800	
	0.0644	0.101	38	
	64	58	900	
	ND	ND	2.8	
			0.9	
	ND	ND	37	
	ND	ND	9	
	ND	ND	5	

	ND	ND	0.5		
	ND	ND	0.43		
	ND	ND	4		
	ND	ND	270		
	ND	ND	560		
	ND	ND	20		
	ND	ND	28		
	ND	ND	1290		
	ND	ND	1200		
	ND	ND	570		
	ND	ND	640		
	ND	ND	76		
	ND	ND	260		
	ND	ND	2256		
	ND	ND	15		
	ND	ND	1.5		
	ND	ND	15		
	ND	ND	151		
	ND	ND	1293		
	ND	ND	1.5		
	ND	ND	15		
	ND	ND			
pH				/	
				/	

---

## **10.**

**10.1.**

**10.2.**

---

	" "	" "	
	" "	" "	

---

	" "	" "	

---

---

**10.3.**

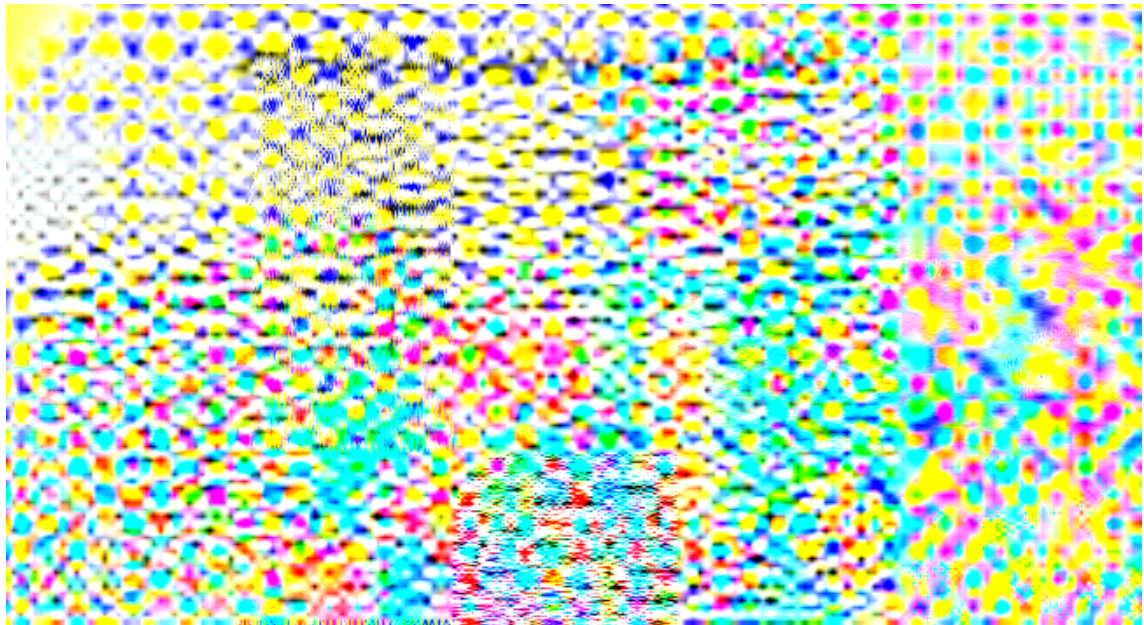

**10.4.**

---

**10.5.**



---

# 11.

## 11.1.

## 11.2.

### 11.2.1.

### 11.2.2.



---

**11.4.**

**11.4.1.**

**11.4.2.**

**11.4.3.**

---

**11.5.**

---

## 11.6.

